

Nikon 28Ti FCA 28001
QUARTZ DATE

DISASSEMBLING / ASSEMBLING / ADJUSTMENT

Nikon | NIKON CORPORATION
Tokyo, Japan

DISASSEMBLING / ASSEMBLING / ADJUSTMENT

Note : The following explanation states only the different points from the repair method of FCA22001 (35Ti) .

Regarding other methods of “Disassembling, Assembling, and Adjustment”, please refer to the Repair Manual for FCA22001 (35Ti) .

ASSEMBLING / ADJUSTMENT

HELICOID

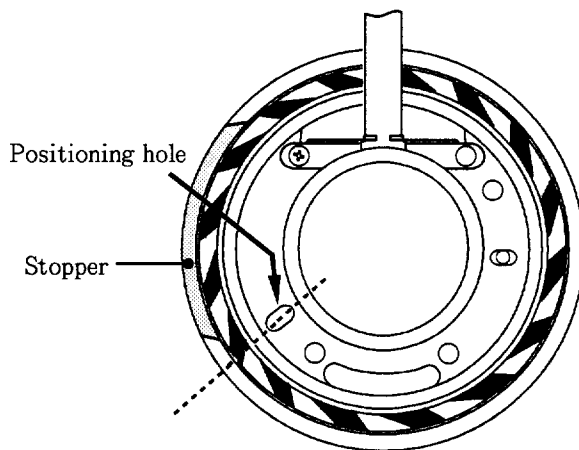
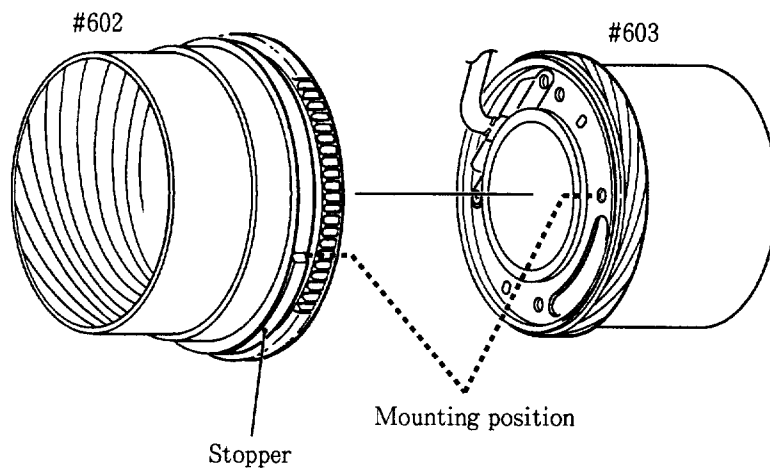

Inspection :

After completion of assembling, the positioning hole should be set to the place as shown left when the edge face of helicoid tubes are fixed at the same height.

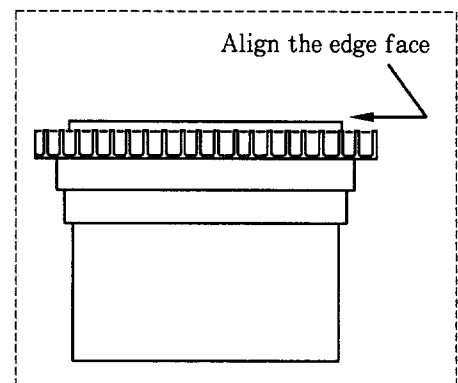

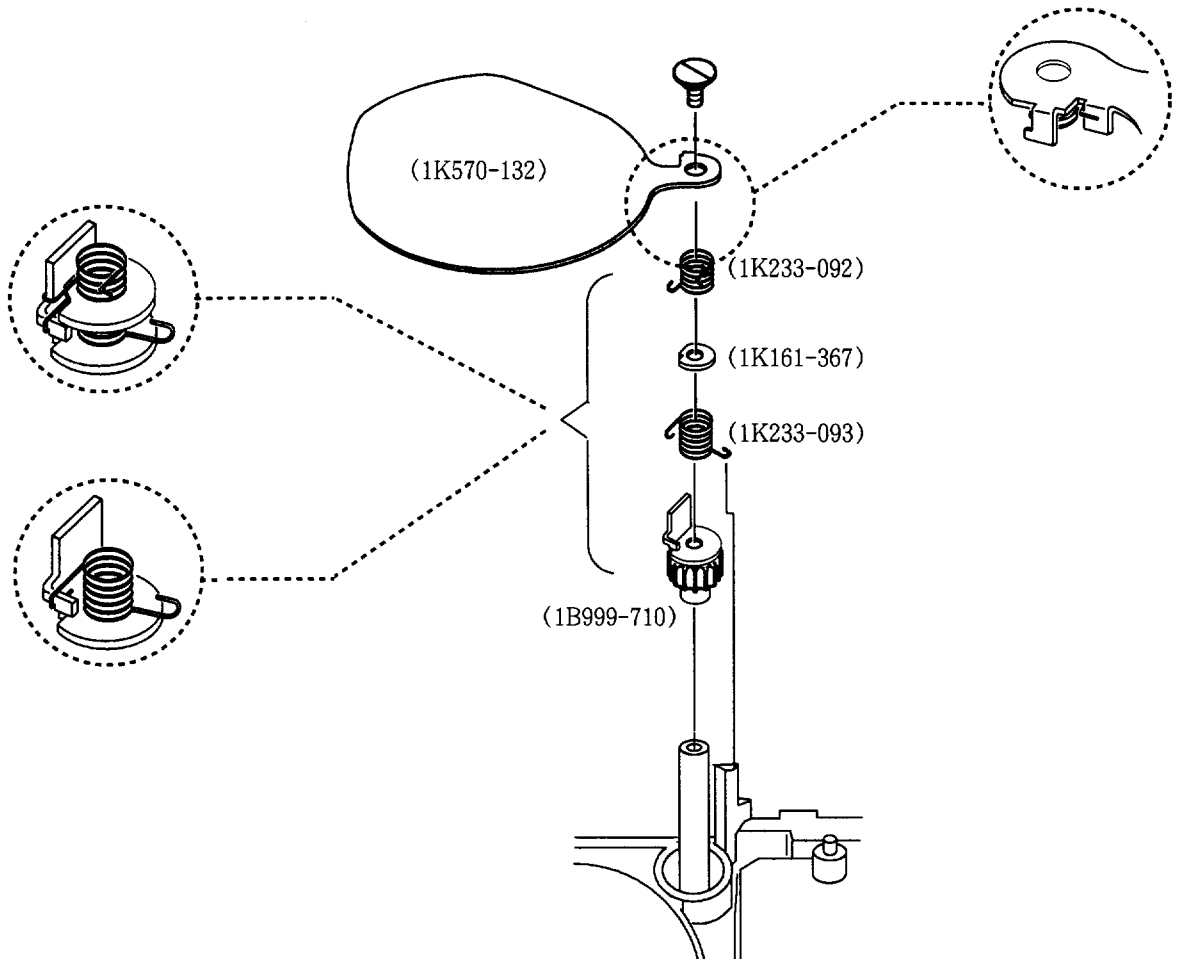

LENS COVER

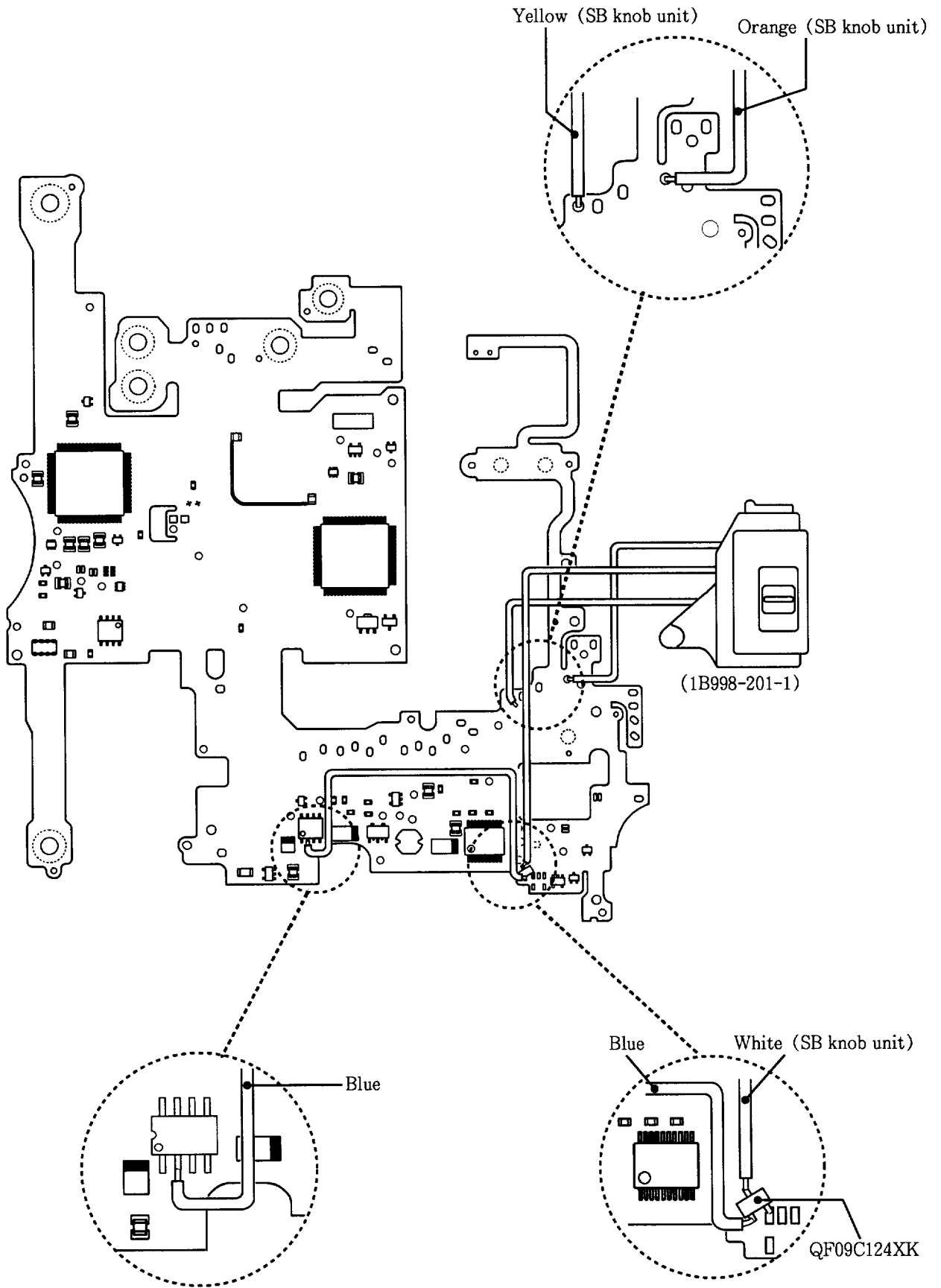

SB KNOB UNIT



作成承認印	配布許可印
	

Nikon 28Ti FCA 28001
 QUARTZ DATE

PARTS LIST (REVISED-1)

修理部品表 (改訂 - 1)

Nikon | NIKON CORPORATION
 Tokyo, Japan

Copyright © 1994 by Nikon Corporation.
 Previous edition copyright © 1995
 All Rights Reserved.
 無断転載を禁ず!!

Jun 12, 1995

展開図 . 部品表編

記号説明 -----	K 1
テープ類TA設定部品一覧表 -----	K 3
リードワイヤー一覧表 -----	K 4
収縮チューブ一覧表 -----	K 5
展開図の見方 -----	K 6
展開図中の部品位置を確認する手順 -----	K 7

Nikon 28 Ti QD

展開図 (Fig. 1 - Fig. 9) -----	F 1
部品表 -----	P 1
部品組品表 -----	P 3

Exploded Drawing & Parts List

MARKS IN THE PARTS LIST -----	K 1
TAPE AND FILMS WITH PREFIX ALPHABETS TA -----	K 3
LEAD WIRE LIST -----	K 4
THERMAL CONSTRUCTION TUBE LIST -----	K 5
HOW TO USE EXPLOSION DRAWINGS -----	K 6
HOW TO FIND THE PATR WITH NUMBER IN THE DRAWING -----	K 7

Nikon 28 Ti QD

Exploded Drawing (Fig. 1 - Fig. 9) -----	F 4
Parts List -----	P 1
Assembly List -----	P 3

作成承認印

配布許可印



Nikon 28Ti FCA 28001
QUARTZ DATE

REPAIR MANUAL

Nikon | NIKON CORPORATION
Tokyo, Japan

© Copyright 1994
ALL RIGHTS RESERVED

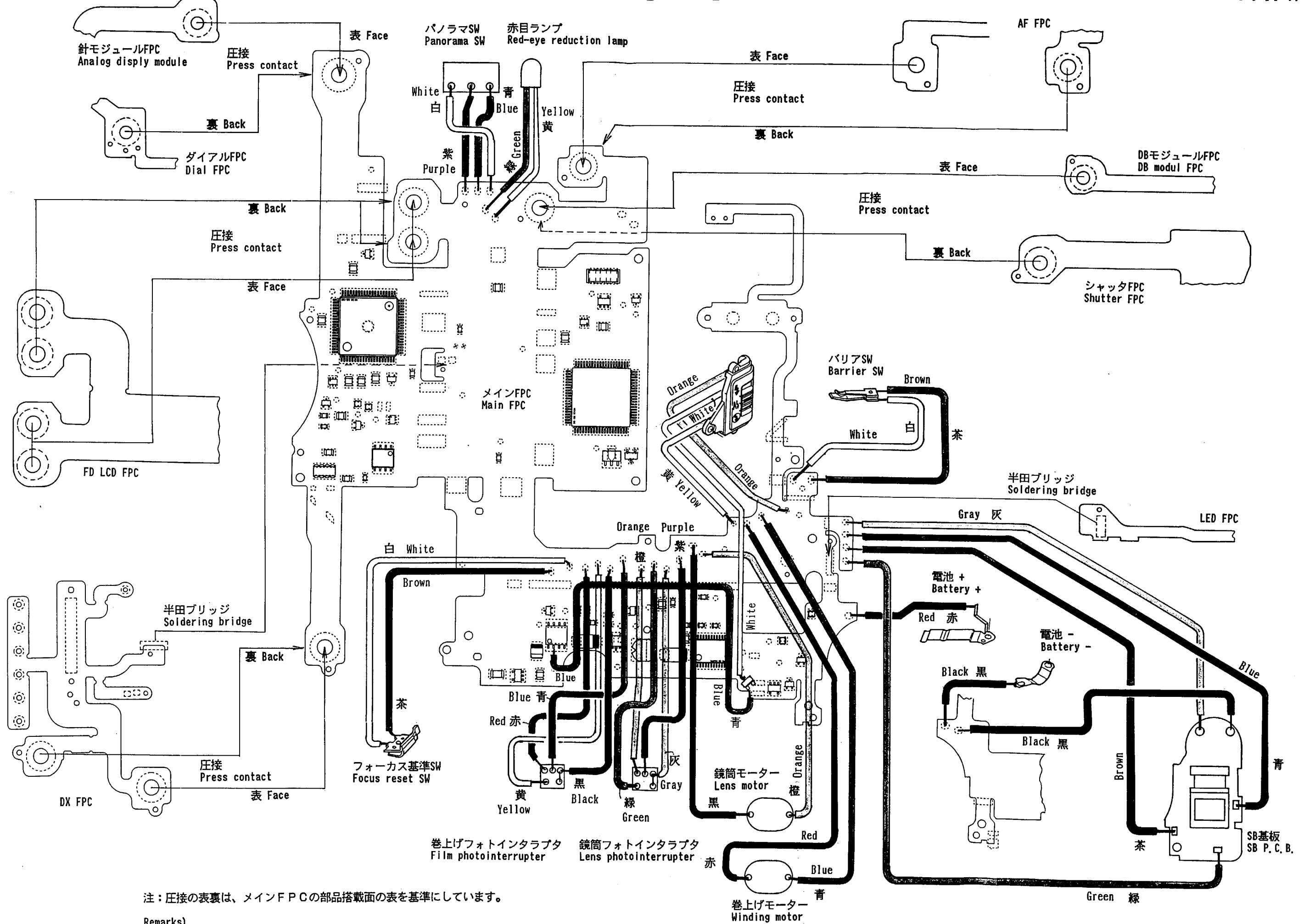

注：圧接の表裏は、メインFPCの部品搭載面の表を基準にしています。

Remarks)
Regarding the instruction for press contact, the side loaded with Main FPC parts is defined as "face" in the drawing.

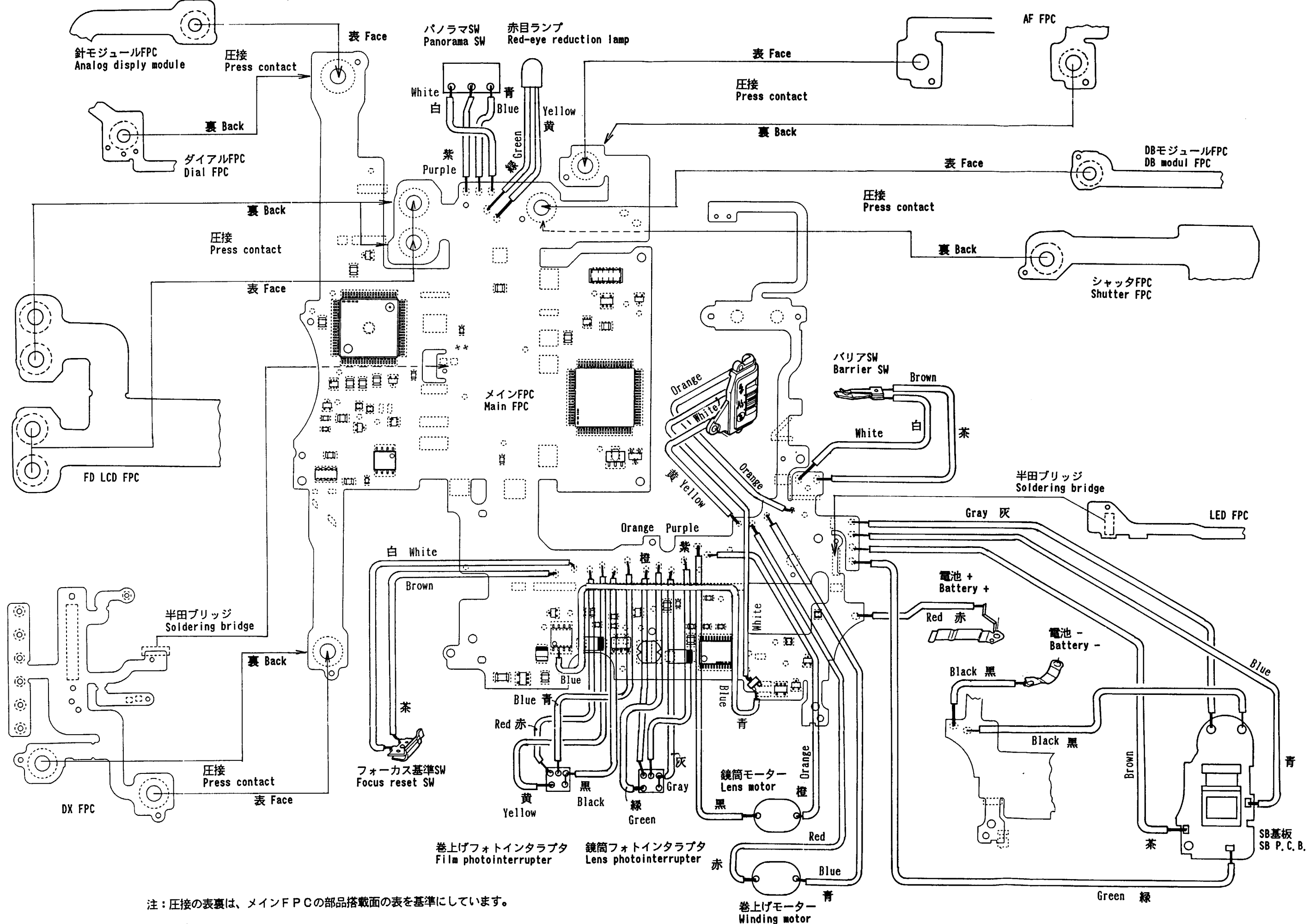

注：圧接の表裏は、メインFPCの部品搭載面の表を基準にしています。

Remarks)
Regarding the instruction for press contact, the side loaded with Main FPC parts is defined as "face" in the drawing.

回路図 Circuit Diagram

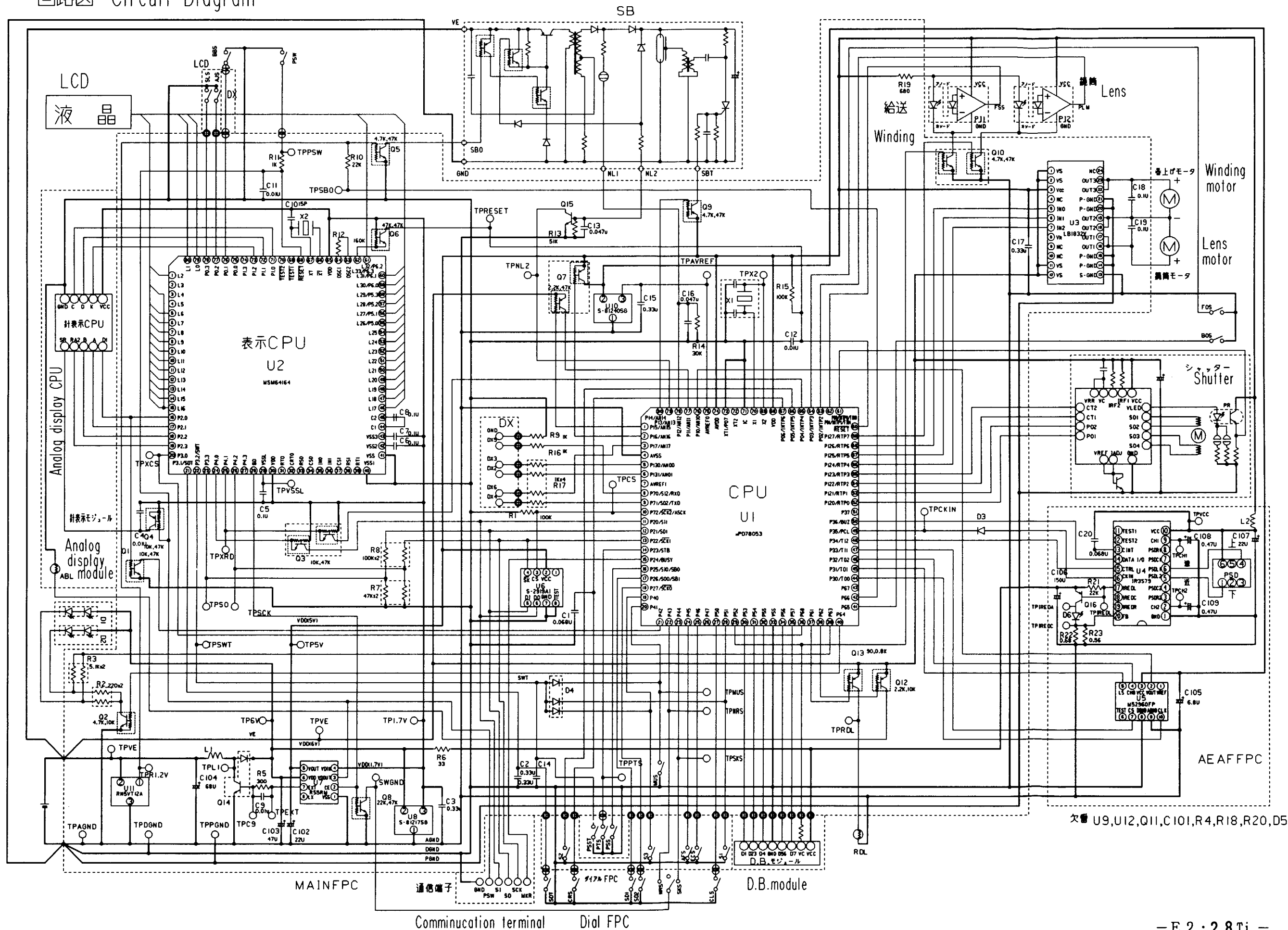

欠番 U9,U12,Q11,C101,R4,R18,R20,D5

E•PROM DATA

ADDRESS, TYPE OF DATA		D A T A		UPPER	LOWER
0	(0H) A	SHUTTER RELEASE TIME			
1	(1H) A	LENS PULSE COUNTER	FILM COUNTER		
2	(2H) --	DISTINGUISH BETWEEN 28Ti AND 35Ti	MODULE ANALOGUE DISPLAY (FIXED)	207	3
3	(3H) A	PA-MODE PRESENT POSITION	AF-MODE PRESENT POSITION		
4	(4H) A	COUNTER MODE PRESENT POSITION	+/- MODE PRESENT POSITION		
5	(5H) A		KEEP SELECTION OF CF-MODE		
6	(6H) A	KEEP PREVIOUS MONTH DATA	KEEP PREVIOUS DAY DATA		
7	(7H) A		KEEP PREVIOUS YEAR DATA		
8	(8H) FIXED	JUDGMENT OF REWIND TIME		8	8
9	(9H) FIXED	SHUTTER CONTROL		79	00
10	(AH) FIXED	SHUTTER CONTROL	SHUTTER CONTROL	23	30
11	(BH) FIXED	SHUTTER CONTROL	SHUTTER CONTROL	79	38
12	(CH) FIXED	FILM SUPPLY CONTROL	FILM SUPPLY CONTROL	80	3
13	(DH) FIXED	DATA BACK CONTROL		40	37
14	(EH) ADJ.	AF CORRECTION VALUE 7	AF CORRECTION VALUE 7		
15	(FH) --	AF LEVEL VALUE (FIXED)	AF SHIFT VALUE (ADJ.)	44	
16	(10H) FIXED	LENS BARREL CONTROL		24	00
17	(11H) FIXED	LENS BARREL CONTROL		7	135
18	(12H) FIXED	LENS BARREL CONTROL		00	251
19	(13H) FIXED	LENS BARREL CONTROL		255	5
20	(14H) FIXED	LENS BARREL CONTROL		56	52
21	(15H) FIXED	LENS BARREL CONTROL		60	19
22	(16H) FIXED	PRE-RELEASE TIMER CONTROL	LENS BARREL CONTROL	4	10
23	(17H) FIXED	SHUTTER CONTROL	SHUTTER CONTROL	46	46
24	(18H) --	SHUTTER EXPOSURE CONTROL (ADJ.)	SHUTTER CONTROL (ADJ.)		62
25	(19H) ADJ.	LENS BARREL PULSE SHIFT (BF)			
26	(1AH) --	EXPOSURE CONTROL (ADJ.)	SB CHARGER CONTROL (FIXED)		20

ADDRESS, TYPE OF DATA		D A T A		UPPER	LOWER
27	(1BH) ADJ.	BC LEVEL 2	BC LEVEL 1		
28	(1CH) ADJ.	BU SHIFT 2	BU SHIFT 1		
29	(1DH) ADJ.	BU SHIFT 4	BU SHIFT 3		
30	(1EH) ADJ.	BU SHIFT 6	BU SHIFT 5		
31	(1FH) ADJ.	UN-USED	BU 7		
32	(20H) FIXED	BL	AF CONTROL	36	
33	(21H) FIXED	AE CONTROL	BL	00	60
34	(22H) FIXED	AE CONTROL	AE CONTROL	00	00
35	(23H) FIXED	AE CONTROL	AE CONTROL	00	00
36	(24H) FIXED	AE CONTROL	AE CONTROL	00	00
37	(25H) FIXED	SHUTTER CONTROL	SHUTTER CONTROL	21	26
38	(26H) FIXED	FM CONTROL	SHUTTER CONTROL	82	23
39	(27H) FIXED	AF		255	255
40	(28H) FIXED	LENS BARREL CONTROL		00	255
41	(29H)	FOR PRODUCTION STAGE			
63	(3FH)	FOR PRODUCTION STAGE			

NOTE FOR ABOVE TABLE :

1. VARIATION

- ADJUSTMENT VALUE (ADJ.) : DATA WRITTEN DURING CAMERA ADJUSTMANT.
- FIXED VALUE (FIXED) : DATA IN WHICH A FIXED VALUE IS TO BE WRITTEN.
- FIXED AND ADJUSTMENT (- -) : UPPER DATA AND LOWER DATA ARE DIFFIRENT VARIATION.

2. BOTH UPPER AND LOWER VALUE ARE DECIMAL NUMBER.

記号説明 MARKS IN THE PARTS LIST

(1) 機械標準品

下の表に示す機械標準品の部品番号は品名、種類、呼び径、長さを示しています。

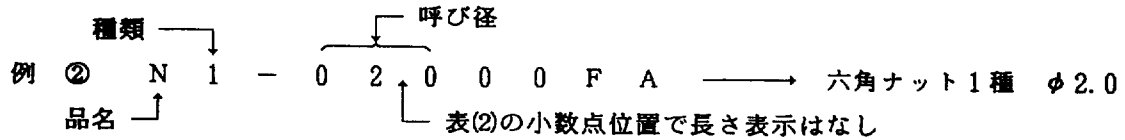
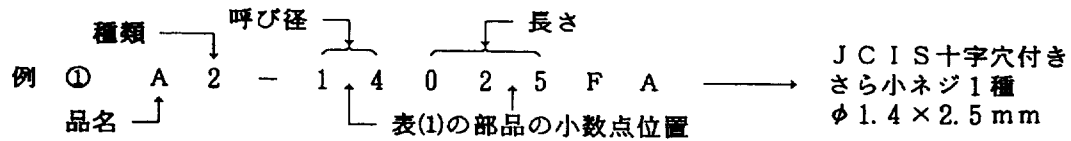

(1) Standard mechanical parts Reference Number in the Parts List

A. Screw · Pin

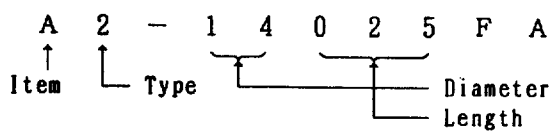

B. Nut · Washer · Snap ring



表 1

品名 Item	種類 Type	品名 Item	種類 Type	
J C I S 十字穴付き小ねじ 1 種 Cross-point screw 1	なべ Pan 1	すりわり付き止めねじ Splitted set screw	丸先 Round point 1	
	さら Countersunk 2		とがり先 Cone point 2	
	丸さら Oval 3		くぼみ先 Half point 3	
J C I S 十字穴付き小ねじ 3 種 Cross-point screw 3	なべ Pan 1	六角穴付き止めねじ Hexagon socket head set screw	とがり先 Cone point 2	
	さら Countersunk 2		くぼみ先 Half point 3	
	丸さら Oval 3		平先 Normal 4	
十字穴付き小ねじ Cross-point screw	なべ Pan 1	六角穴付きボルト Hexagon socket head bolt	M 1 1	
	さら Countersunk 2		M2, M2.6 2	
	丸さら Oval 3	平行ピン Straight pin	ステンレス Stainless steel 5	
	トラス Trus 4		テーパピン Taper pin	2
十字穴付きタップタイ タイトねじ B 型 Cross-point tapped screw B	なべ Pan 1	スプリングピン Spring cotter	一般用 Normal 3	
	さら Countersunk 2		軽荷重用 Light 4	
十字穴付きタップタイ タイトねじ B 型 1 種 Cross-point tapped screw B1	なべ Pan 1	表 2		
	さら Countersunk 2	品名 Item	種類 Type	
	丸さら Oval 3	六角ナット Hexagon nut	K	1 種 Type 1 1 1 種 Type 3 3
十字穴付きタップタイ タイトねじ B 型 3 種 Cross-point tapped screw B3	なべ Pan 1	平座金 Washer	R	小形丸 1 みがき丸 2
	さら Countersunk 2	ばね座金 Spring washer		5
	丸さら Oval 3	E 型止め環 E-snap ring	S	E 型 Type E 1 G 型 Type G 2 GS 型 Type GS 3

(2) 販売区分欄 The term of sale colum

記号 Mark	説明	Explanation
○	Can be Supplied individually	単独部品として販売するもの
△	Not supplied individually but only as subassembly.	部組品でなければ販売しないもの
○△	Supplied either as part or subassembly	単独部品でも部組品でも販売するもの
×	Not considered as repair part	修理部品と考えないもの
*	Should be sent to the factory if the repair needed.	単体では交換できないので、組む場合に工場での加工が必要なもの
☒	Delivered as a product from the sales department (i.e., not supplied as repair part)	商品として販売店で販売しているもの (修理部品扱いはしない)

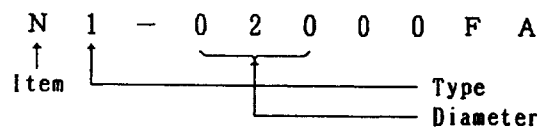
(3) 備考欄 The remarks colum

P-601M	Part number used in common	共通部品番号
(Blue ×125mm)	Lead wire (color × length)	コードの色と長さ
53F-2013 (FM-780028)	Technical information ref. number (number in parenthesis; English edition)	製品技術資料No ()内は英文
(2.1×3.8 ×0.07)	Washer (internal diameter × external diameter×thickness)	ワッシャー (内径×外径×厚さ)
(Black)	Black-finished parts	黒部品
(d=0.2)	Diameter of wire	線型=0.2
(t= 1)	Thickness	厚さ=1
Rev.	Revision	訂正
Add.	Addition	追加
Dis.	Discontinuation	廃止
OLD	Parts of the intial design	旧部品
◆	Limited part	R P 限定出庫部品
RP-9001	Repair part information No.	R P 情報No.
R1... D1.... W1... C1... Q1.... P1...	Abbreviation for electronic part	電気部品記号
TA-0003	Number (TA-****) are order numbers of adhesive tape. (For the order of adhesive tape, the number 1K***-*** is not use).	接着テープ要求部番 (1K***-*** では部品要求できません。)
W-0056BE	Number (W-0056BE) are order numbers of Lead wire. (For the order of Lead wire, the number 1K***-*** is not use).	リードワイヤ要求部番 (1S***-*** では部品要求できません。)

* VERSATILE PART

* 既出部品

Apart maked with this pentagonal symblo is used commonly in the arcitecture of other products. That is called "VERSATILE PART". Note that every part, bearing new part number of eleven places, will turn into a VERSATILE PART when it is used in the design of future product.

テープ類TA設定部品一覧表

TAPES AND FILMS WITH PREFIX ALPHABETS TA Dec. 17, 1991

部品 No. Part No.	名称 Name of part	色 Color	厚さ Thickness (t=mm)	幅 Widths (mm)	長さ Length (m)	要求単位 Q'ty for a unit for ordering
TA-0001	ポリエステルフィルム Tape	透明 Transparent	0.025	10	30	1巻 1 roll
TA-0002	ポリエステルフィルム Tape	透明 Transparent	0.025	20	30	1巻 1 roll
TA-0003	両面接着テープ Both sided adhesive tape	白 White	0.16	10	2	1巻 1 roll
TA-0004	両面接着テープ Both sided adhesive tape	黒 Black	0.14	12	50	1巻 1 roll
TA-0005	ポリエステルフィルム Tape	黄 Yellow	0.06	19	66	1巻 1 roll
TA-0006S	アセテートクロス(シート) Tape (200x120/sheet)	黒 Black	0.23	6	200 (mm)	1set (20pcs)
TA-0007	銅箔導電性 Tape, copper foil	銅箔 Copper foil	0.11	4	6	1巻 1 roll
TA-0008	ポリエステルフィルム Tape	透明 Transparent	0.055	30	30	1巻 1 roll
TA-0009	カプトンフィルム Tape	琥珀 Amber	0.07	6	30	1巻 1 roll
TA-0010	両面接着テープ Both sided adhesive tape	乳白色 Opal	0.16	15	36	1巻 1 roll
TA-0011	ポリエステルフィルム Tape	黒 Black	0.06	10	30	1巻 1 roll
TA-0012	ポリエステルフィルム Tape	透明 Transparent	0.025	6	30	1巻 1 roll
TA-0013	アセテートクロス(シート) Tape (200x120/sheet)	黒 Black	0.23	20	200 (mm)	1set (20pcs)

展開図の見方 How to use explosion drawings

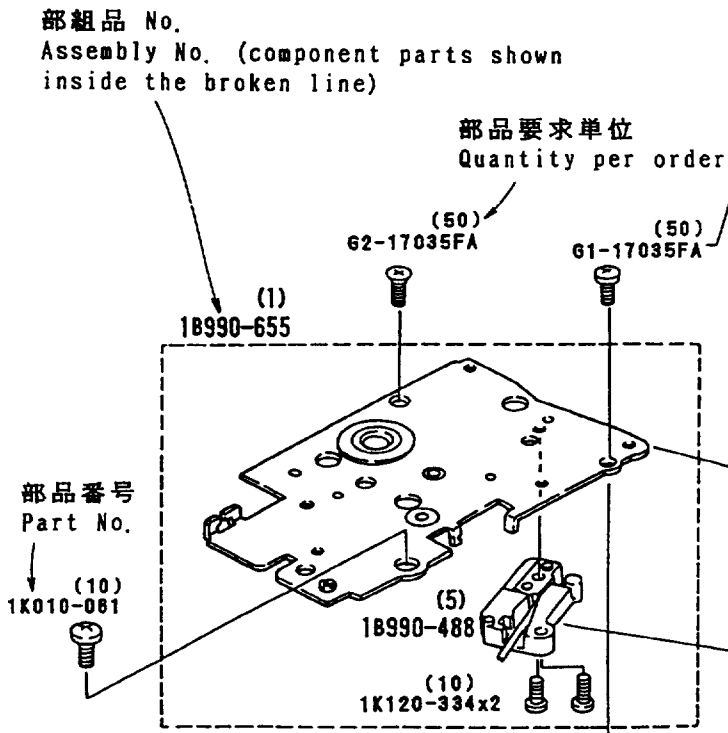

項目 Part Classification	販売区分 Term of Supply	記号 Mark
破線外で部番の入っているもの Part with Part No., shown outside the broken line	単部品で要求できるもの Available as individual part	○
破線外で部番のないもの Part without Part No., shown outside the broken line	修理部品と考えないもの Not available as repair part	×
破線内で部番のないもの Part without Part No., shown inside the broken line.	部組品でなければ要求できないもの Available only as assembly.	△
破線内で部番の入っているもの Part with Part No., shown inside the broken line	単部品でも部組品でも要求できるもの Available as assembly or individually	○△

展開図中の部品位置を確認する手順
HOW TO FIND THE PART WITH PART NUMBER
IN THE DRAWING

部品表 Parts List

部品番号 Part No.	補助番号 Ckt No.	名称 Name	1台分 個数 Qty Per Unit	部組品番号 Assembly	参照 図番 Fig No	販売区分 Class. of Salabil- ity	備考 Remarks	要求単位 Order Unit Qty
*1K240-516	573	シュー座板バネ Accessory shoe spring	1	18990-712-2	9 A1	○△	F-401S F-601	5
*1K240-713-1	527	ロックバネ B Lock spring B	1	18990-712-2	10 A2	○△		5

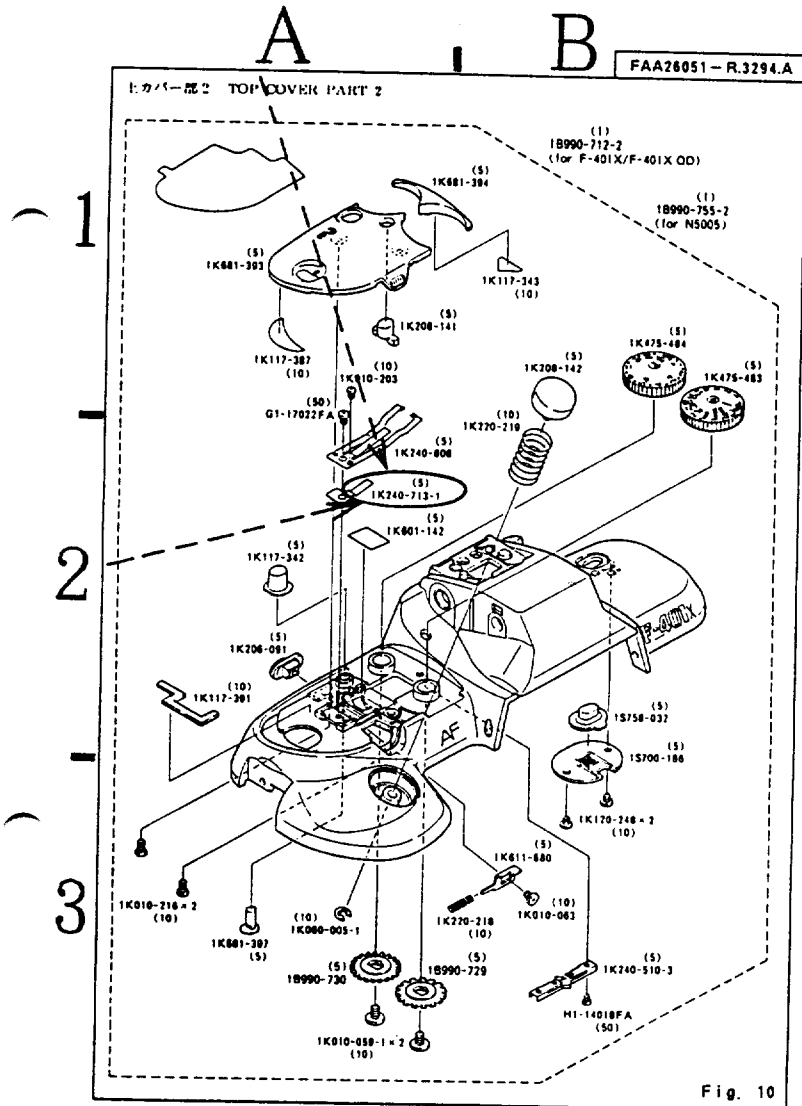

① 部品表の参照図番欄のコードを見る。

Please refer to the letters written in the Fig. No. Column.

② 9, 10等の数字は図面番号を示す。

The numbers 9 and 10 mean the Fig. number.

③ A1, A2等のアルファベットと数字の組み合わせは、図面中の部品の位置を示す。

例 A, B... は横方向の位置を示す。
1, 2... は縦方向の位置を示す。

※ よって1K240-713-1 はAと2が示す範囲内にある。

The combinations of alphabets and numbers, A1 and A2, point out the place of relevant parts in the drawing.

Example)

Alphabets like A and B point out the places along the horizontal direction.

Numbers like 1 and 2 point out the places along the vertical direction.

※ It means that the part No. 1K240-713-1 is existing in the area where A and 2 are crossing.

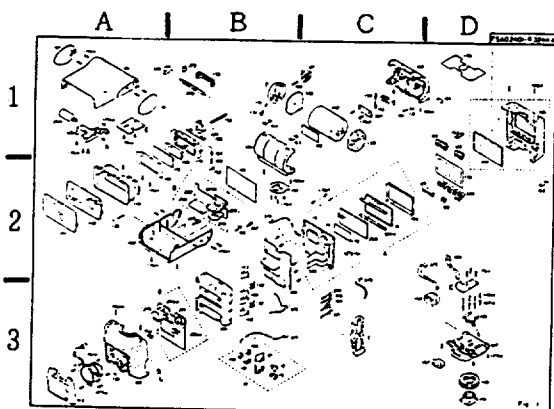

④ 例外 -- ビス, ワッシャー等は Fig No. のみ記載する。

As for screws and washers and the like, no code number showing existing place is described in the Fig. No. Column, but only the relevant drawing number (Fig. No.) is stated.

A

B

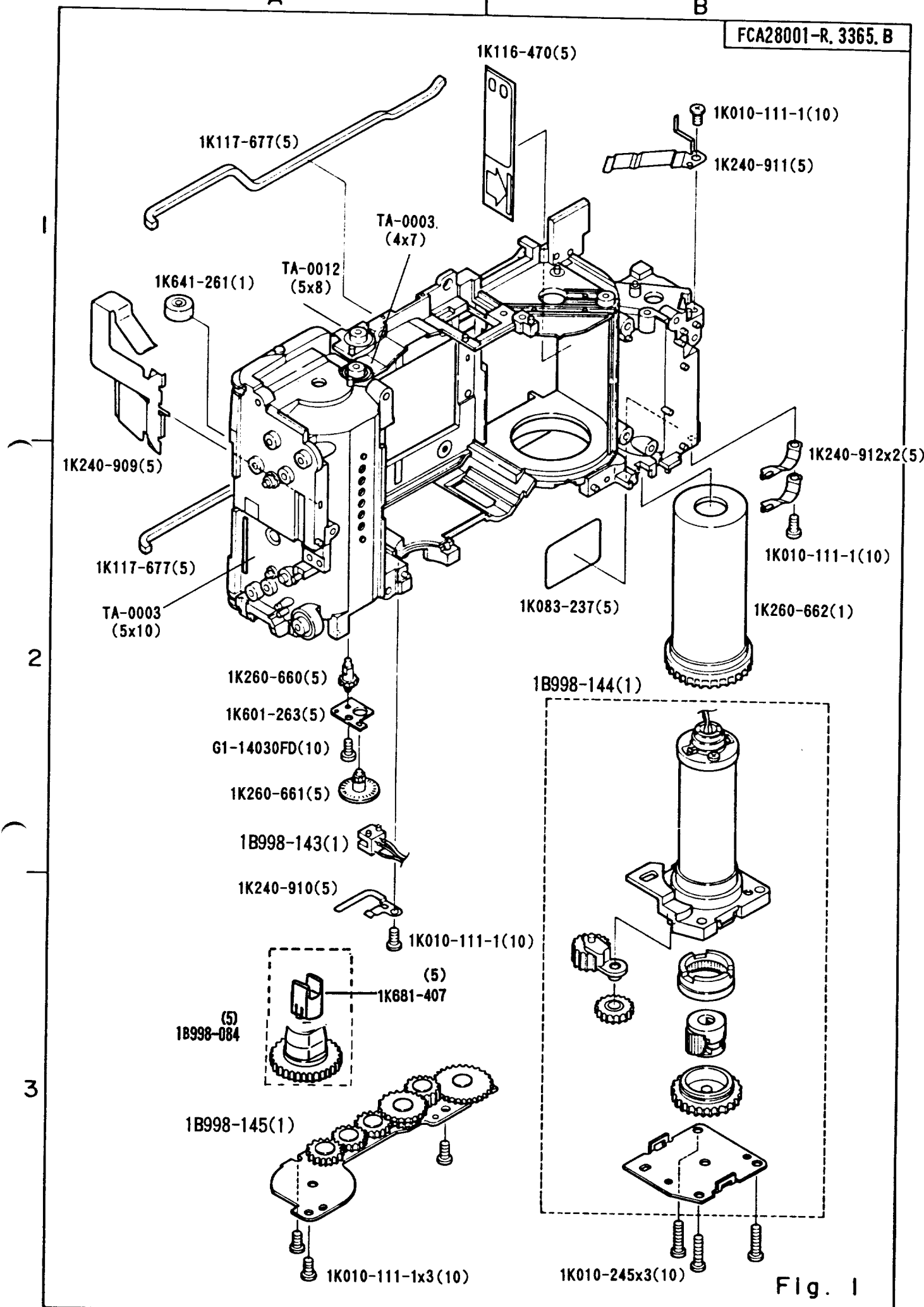

Fig. 1

A

B

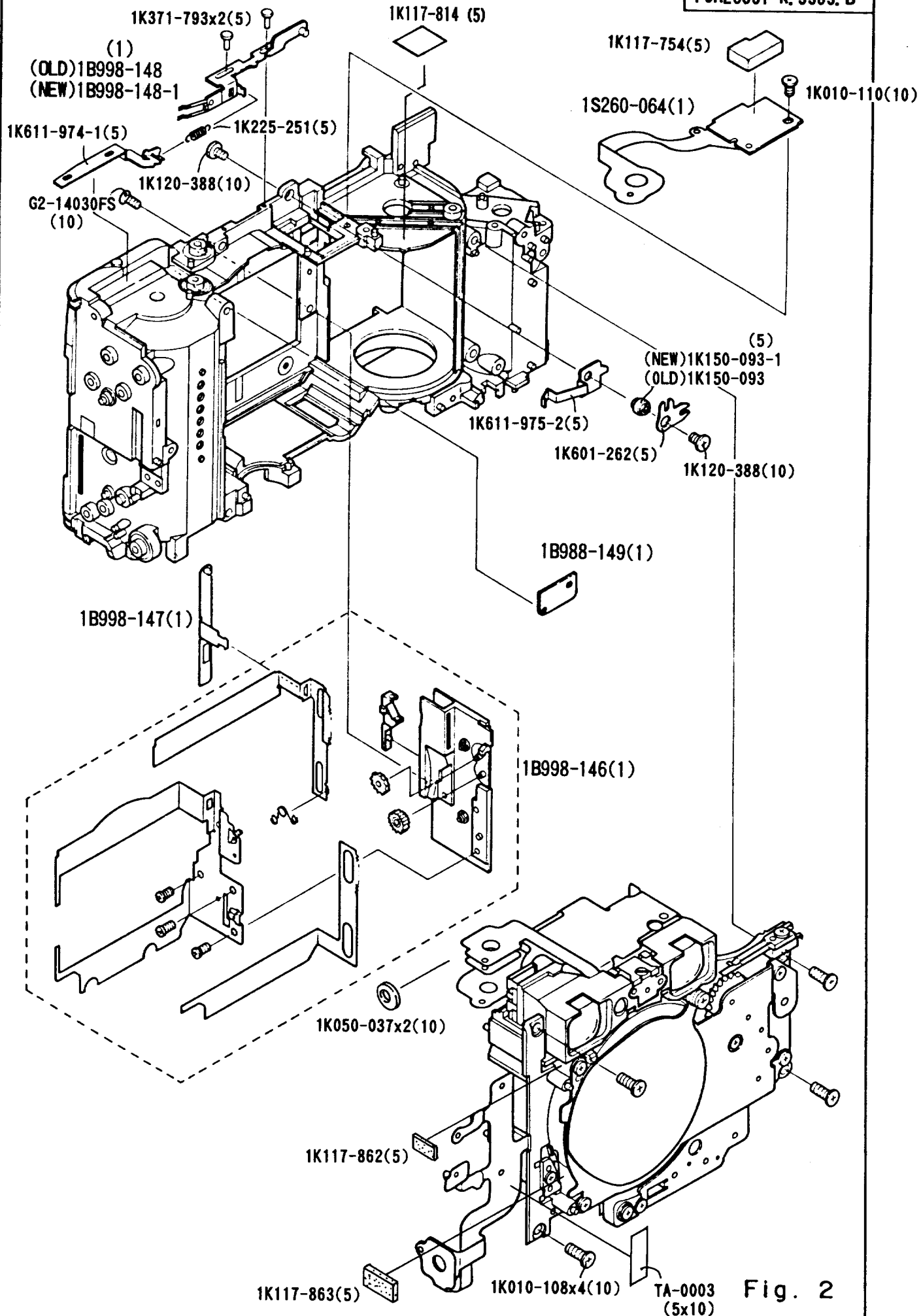
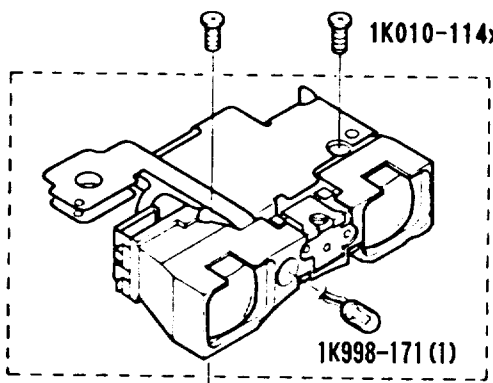

Fig. 2

A

B



(1)
 (OLD)1B998-173
 (NEW)1B998-173-1

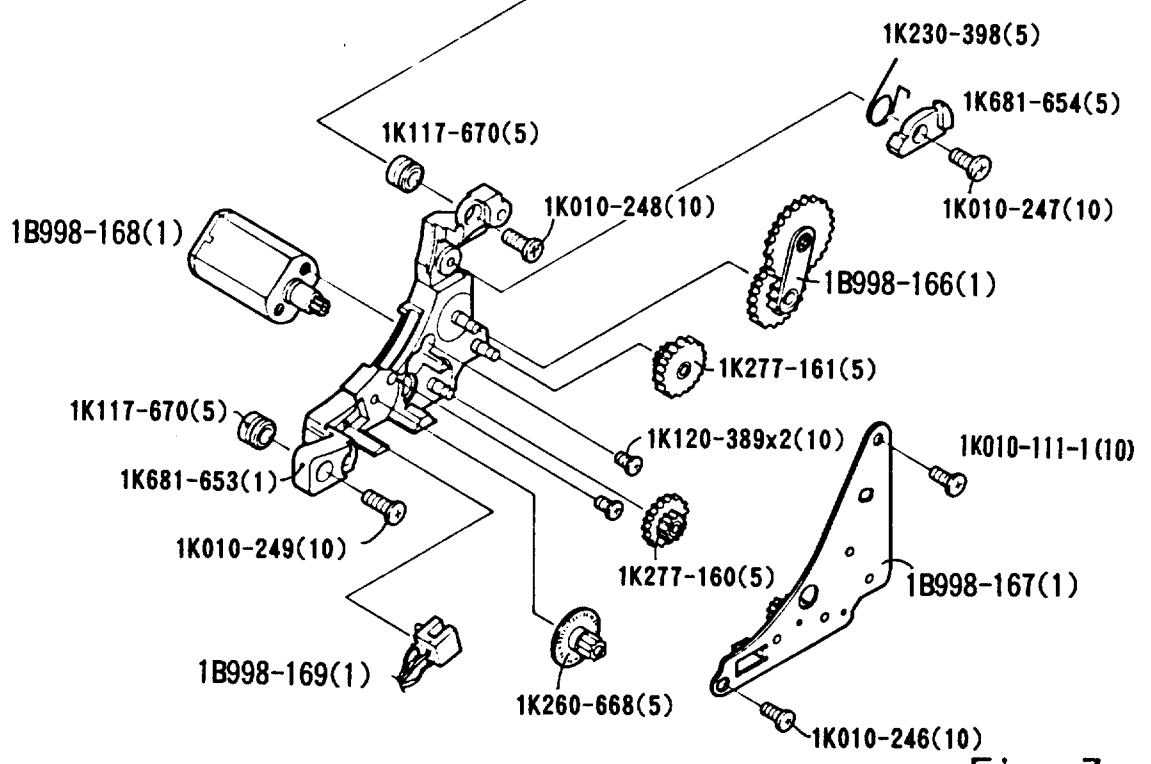
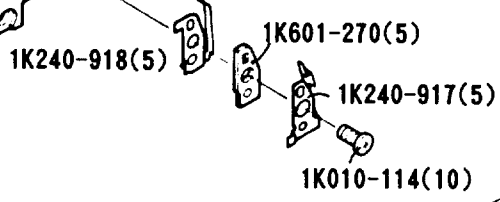
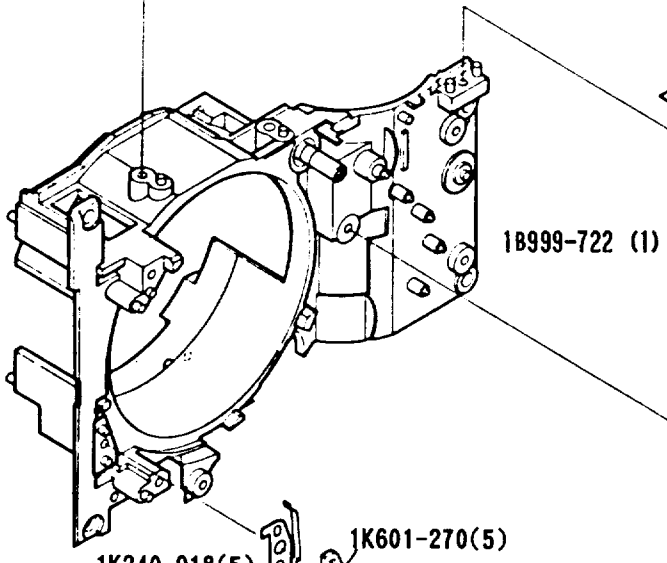
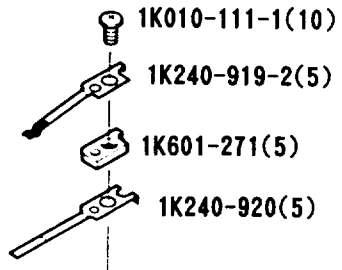

Fig. 3

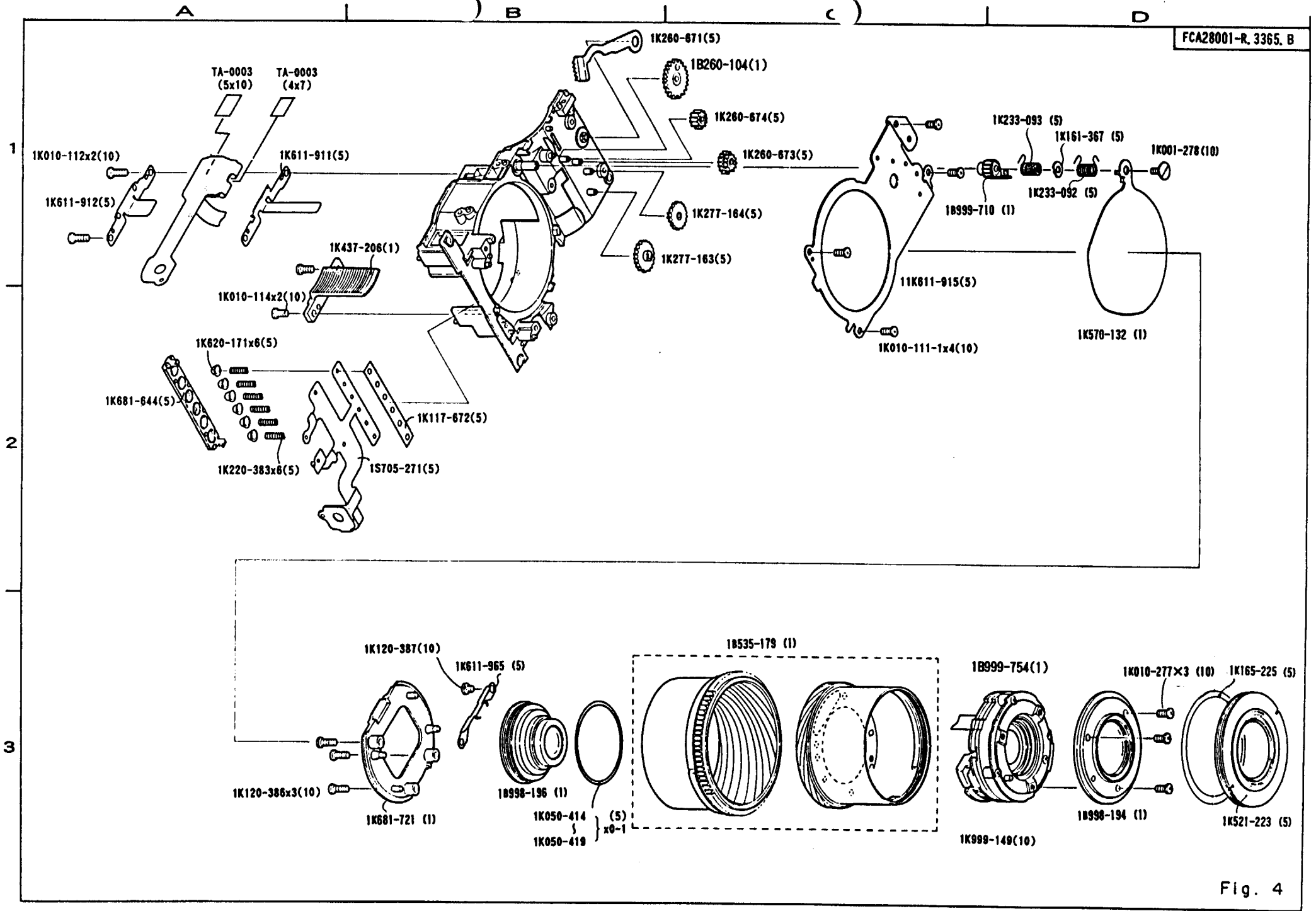

Fig. 4

-F4, 28T1-

A

B

FCA28001-R. 3365. B

18999-708 (1)

1K116-750(5)

1K116-970(5)

1G308-046 (1)

1G042-006 (1)

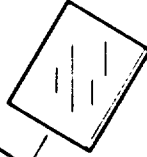
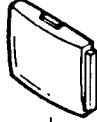
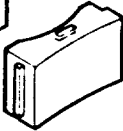
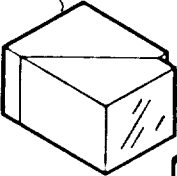

1K117-815(5)

1K010-114x2(10)

1K010-111-1(10)

1S999-105(1)

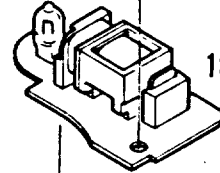

1S999-106(1)

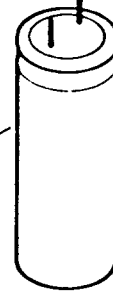

1S999-108 (1)

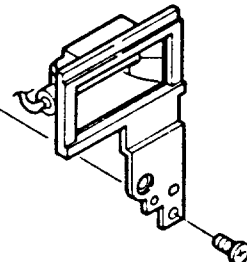

1K010-111-1(10)

TA-0012 (5x11)

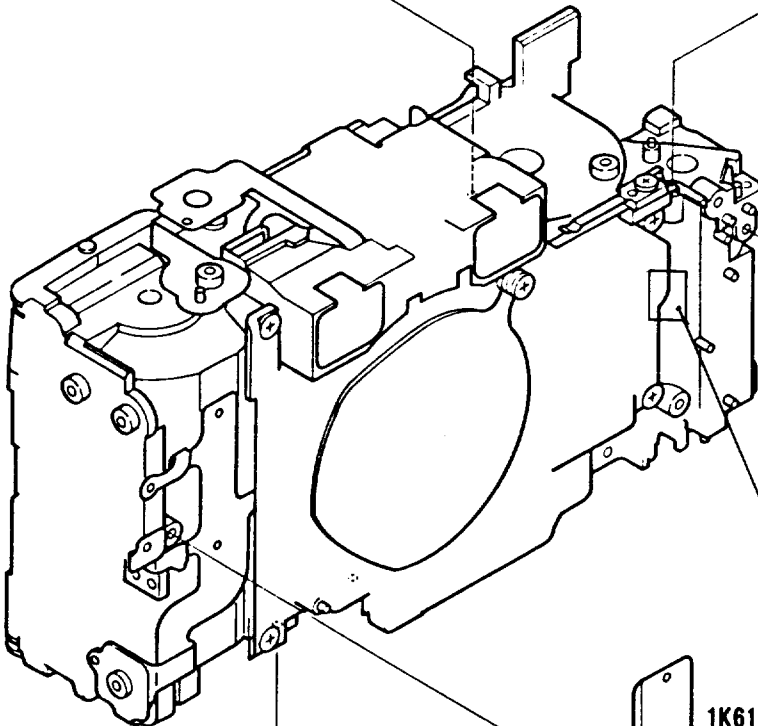

1K611-918(5)

1K010-110(10)

1K681-629(5)

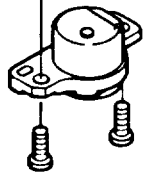

1K010-114x2(10)

Fig. 5

A

B

FCA28001-R. 3365. B

TA-0009

(10)
(OLD)1K010-117
(NEW)1K010-245

1K010-243(10)

R1-02000FY(10)

1K010-243(10)
1K611-916(5)
1K165-226(5)

1K611-916(5)
1K117-671(5)

1B998-150-1(1)

1B998-189(1)

TA-0013
(10x10)

1K117-911(5)

1K117-671x2(5)
1K611-917(5)
1K010-243x2(10)

2

1K117-933(5)

1K117-812(5)

1K117-671(5)
1K611-916(5)
1K010-243(10)

1K010-251(10)

1B002-079(1)

1K010-112x2(10)

1S020-105-3(1)

1S424-036(5)

1B998-185(1)

3

1B998-201-1(1)

1S190-029(5)
1S223-007(5)

1K010-110(10)

A

(10)
(OLD)1K010-250
(NEW)1K010-272

1B002-078(1)

1K010-112(10)

1K010-110(10)

1K601-272(5)

Fig. 6

-F7. 28 T1-

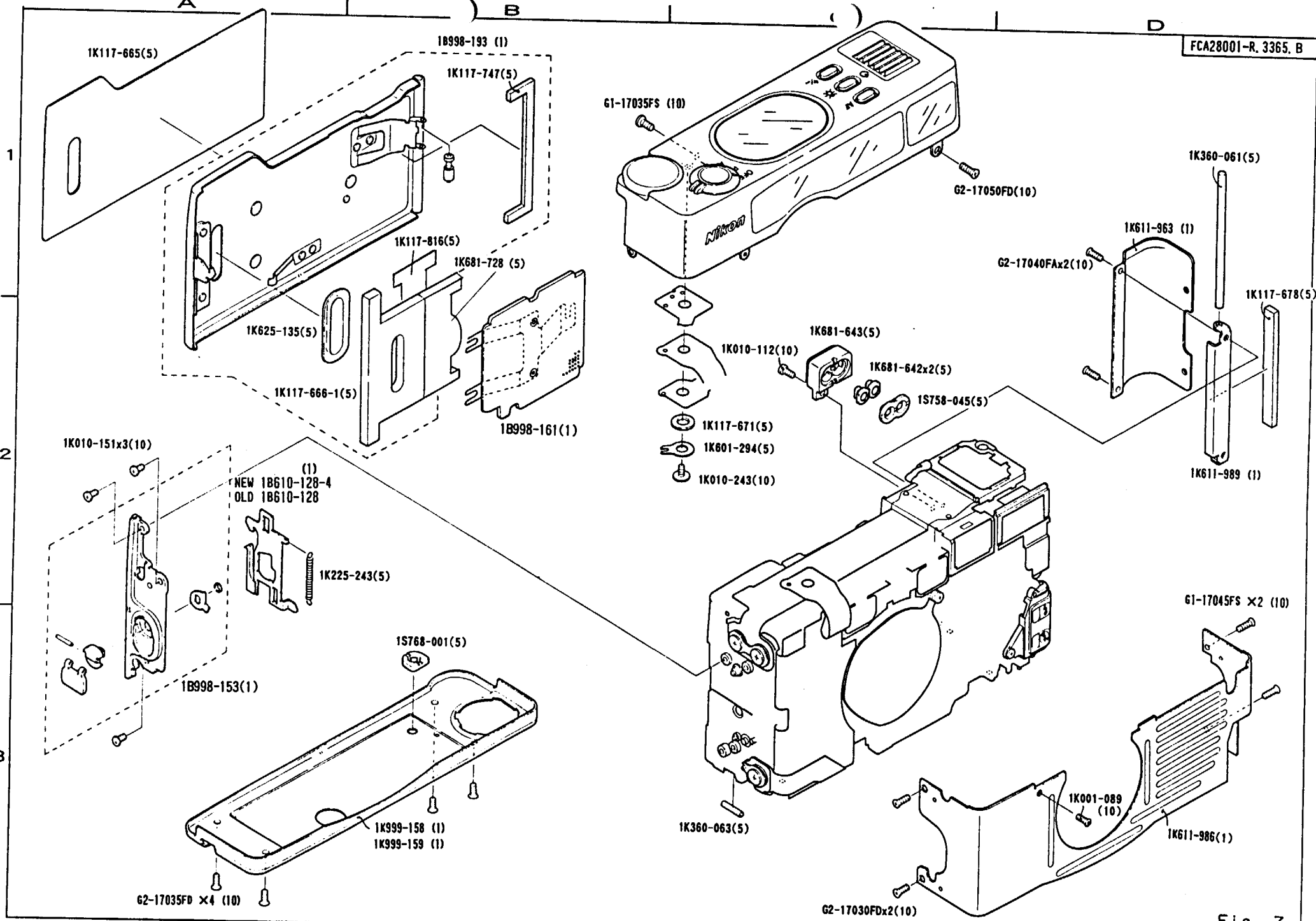

Fig. 7

A

B

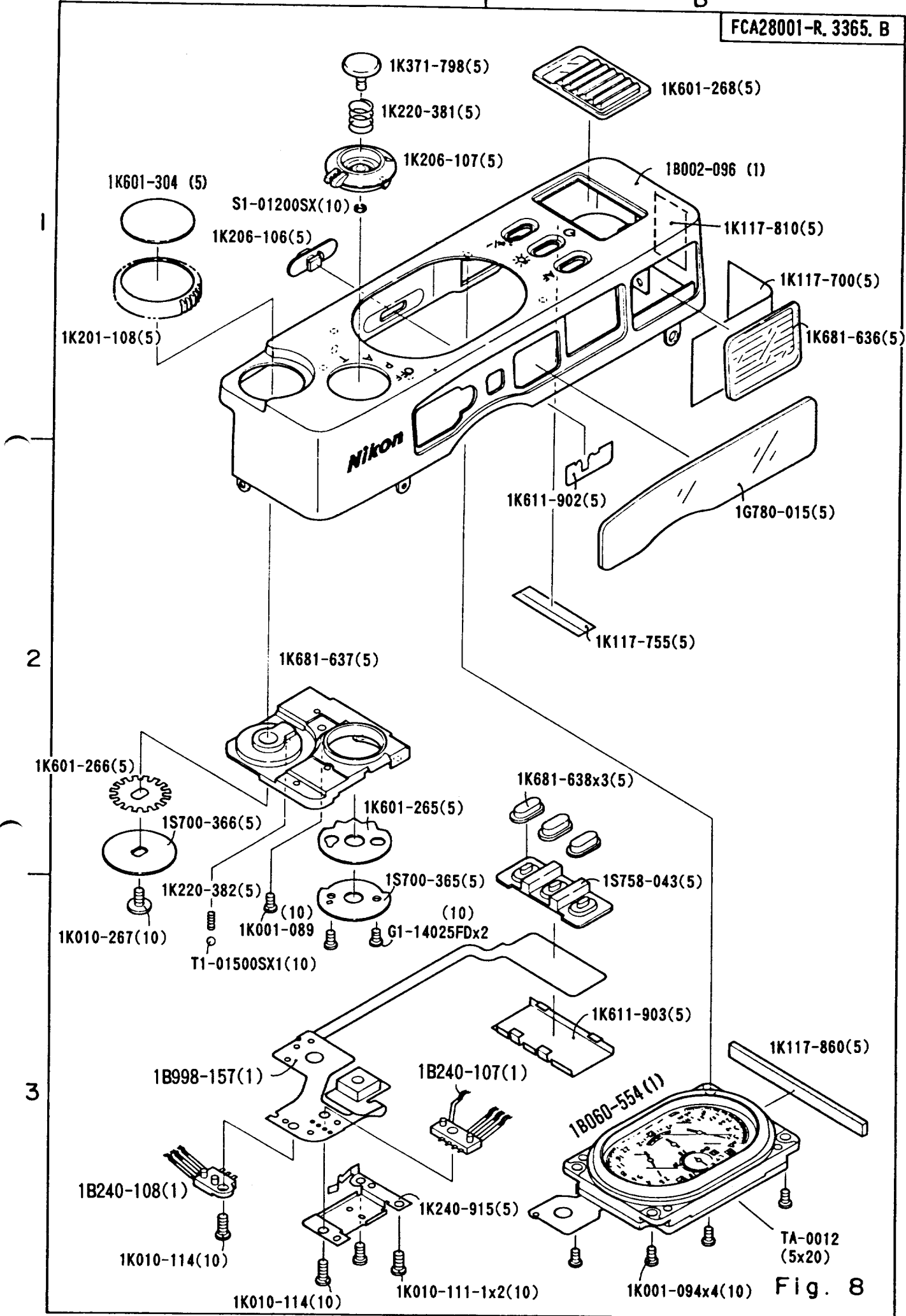

Fig. 8

A

B

FCA28001-R. 3365. B

△ 1B998-165(1)

1B998-164(1)

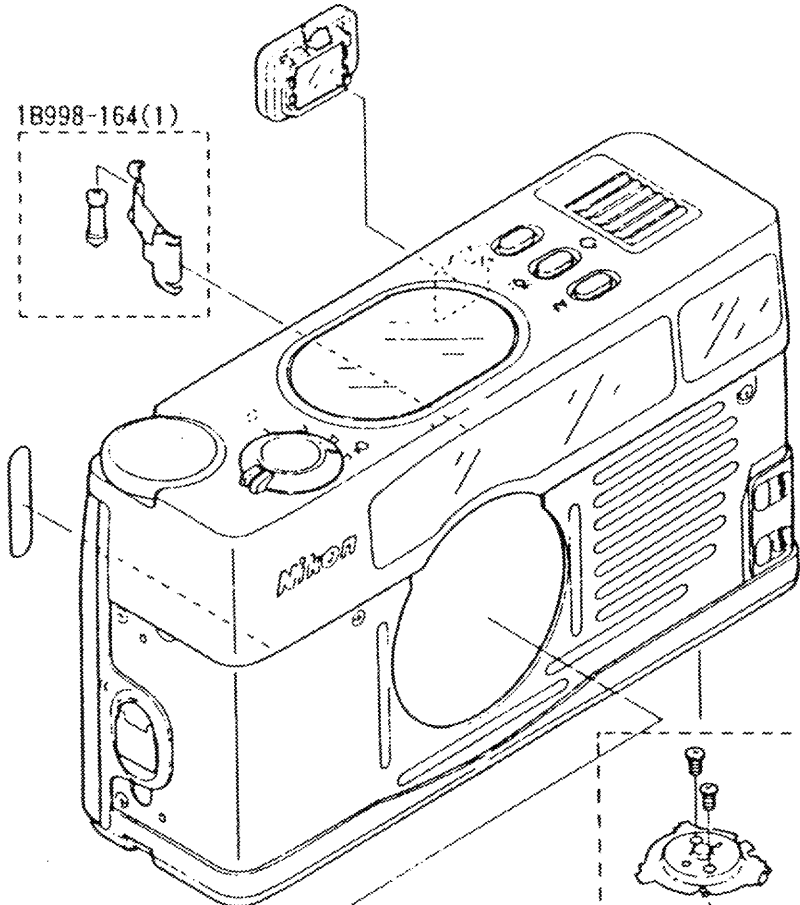
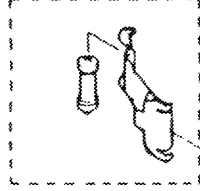

1B998-163-1(1)

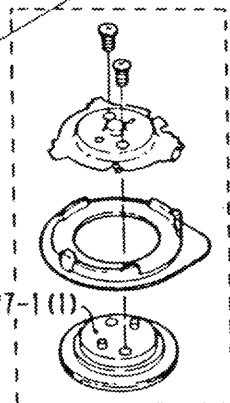

1B999-627-1(1)

1K117-663(5)

2

1K117-807(5)

1K601-303 (1)

3

1K117-664(5)

1K641-260(5)

1K087-420 (5)

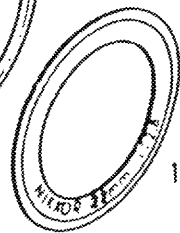
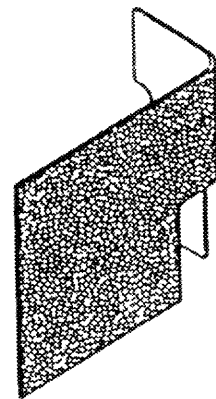
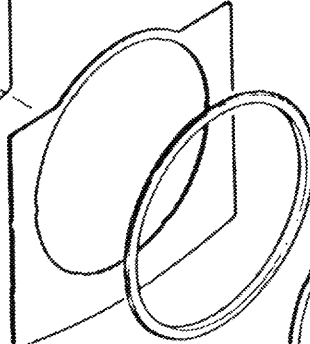
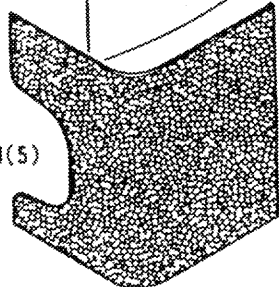

Fig. 9

部品表 Parts List

FCA28001-R. 3365. B

部品番号 Part No.	補助番号 Ckt No.	名称 Name	1台分 個数 Q'ty Per Unit	部組品番号 Assembly	参照 図番 Fig. No.	販売区分 Class. of Salabil- ity	備考 Remarks	要求単位 Order Unit Q'ty
* 1K001-089	840	Screw	2		7.8	○		10
* 1K001-094	886	Screw	4		8 B3	○		10
1K001-278	808	Screw	1		4 D1	○		10
* 1K010-108	801	Screw	4		2 B3	○	FEA50001 FCA13001	10
* 1K010-110	816	Screw	4		2.5 6	○	FCA13001 FCA09002	10
* 1K010-111-1	814	Screw	16		1.3 4.5 8	○		10
* 1K010-112	813	Screw	6		4.6 7	○	FCA18001 FCA13001	10
* 1K010-114	812	Screw	11		3.4 5.8	○	FCA18001 FCA13001	10
* 1K010-117	809	Screw	1		6 B1	○		10
* 1K010-151	815	Screw	3		7 A2	○	FCA09002	10
* 1K010-243	804	Screw	6		6.7	○		10
* 1K010-245	811	Screw	4		1.6	○		10
* 1K010-246	841	Shoulder screw	1		3 B3	○		10
* 1K010-247	842	Shoulder screw	1		3 B3	○		10
* 1K010-249	844	Shoulder screw	1		3 A3	○		10

部品表 Parts List

FCA28001-R. 3365. B

OLD
NEW

部品番号 Part No.	補助番号 Ckt No.	名称 Name	1台分 個数 Q'ty Per Unit	部組品番号 Assembly	参照 図番 Fig. No.	販売区分 Class. of Salabil- ity	備考 Remarks	要求単位 Order Unit Q'ty
* 1K010-250	845	Shoulder screw	1		6	○		10
* 1K010-272	848				B3			
* 1K010-251	847	Shoulder screw	1		6 A2	○		10
* 1K010-267	807	Screw	1		8 A3	○		10
1K010-277	817	Screw	3		4 D3	○		10
* 1K050-414	612A	B・f調整環 (t=0.05) Adjust ring . BF	1		4 B3	○		5
* 1K050-415	612B	B・f調整環 (t=0.06) Adjust ring . BF	1		4 B3	○		5
* 1K050-416	612C	B・f調整環 (t=0.07) Adjust ring . BF	1		4 B3	○		5
* 1K050-417	612D	B・f調整環 (t=0.08) Adjust ring . BF	1		4 B3	○		5
* 1K050-418	612E	B・f調整環 (t=0.09) Adjust ring . BF	1		4 B3	○		5
* 1K050-419	612F	B・f調整環 (t=0.10) Adjust ring . BF	1		4 B3	○		5
* 1K083-237	196	電池シール Battery seal	1		1 B2	○		5
1K087-420	616	銘板 Name plate	1		9 B3	○		5
* 1K116-470	195	フィルムガイドシール Seal , Film guide	1		1 B1	○	FCA09002 FCA13001	5

部品表 Parts List

FCA28001-R. 3365. B

部品番号 Part No.	補助番号 Ckt No.	名称 Name	1台分 個数 Q'ty Per Unit	部組品番号 Assembly	参照 図番 Fig. No.	販売区分 Class. of Salabil- ity	備考 Remarks	要求単位 Order Unit Q'ty
* 1K116-970	527	接眼モルト Sponge , Eyepiece	1	1B999-708	5 A1	○△	FRW52801	5
* 1K117-663	110	革(右側) Leatherette , SB side	1		9 B2	○		5
* 1K117-664	111	革(左側) Leatherette , Release button side	1		9 A3	○		5
* 1K117-665	121	裏蓋革 Leatherette , Camera back	1		7 A1	○		5
* 1K117-666	127	パトローネモルト Spnge , Patorone	1		7 B1	○		5
* 1K117-670	650	ゴムブッシュ Rubber bush	2		3 A3	○		5
* 1K117-671	702	圧接ゴム Rubber , Press contact	5		6.7	○		5
* 1K117-672	751	両面テープ . DX Double sided adhesive tape .DX	1		4 B2	○		5
* 1K117-674	754	両面テープ 1 4×7 Double sided adhesive tape 1	2		1.4	×	RP-9454 TA-0003	1 roll
* 1K117-675	755	両面テープ 2 5×10 Double sided adhesive tape 2	3		1.2 4	×	RP-9454 TA-0003	1 roll
* 1K117-677	191	裏蓋モルト1 Sponge 1 , Back door	2		1 A1	○		5
* 1K117-678	192	裏蓋モルト2 Sponge 2 , Back door	1		7 D2	○		5
* 1K117-700	305	ストロボシート Sheet , SB	1		8 B1	○		5
* 1K117-747	133	裏蓋モルト4 Sponge 4 , Back door	1	1B998-193	7 B1	○△		5
* 1K117-750	525	目隠しモルト Shield sponge , Finder	1	1B999-708	5 A1	○△		5

部品表 Parts List

FCA28001-R. 3365. B

部品番号 Part No.	補助番号 Ckt No.	名称 Name	1台分 個数 Qty Per Unit	部組品番号 Assembly	参照 図番 Fig. No.	販売区分 Class. of Salabil- ity	備考 Remarks	要求単位 Order Unit Qty
* 1K117-754	172	DB モルト DB sponge	1		2 B1	○		5
* 1K117-755	147	横カバー目隠しシート Side cover shield sheet	1		8 B2	○		5
* 1K117-801	759	圧接絶縁テープ , AE圧接 5×8 Insulation tape.Press contact AE	1		1 A1	×	TA-0012	1 roll
* 1K117-802	760	Mリード線固定テープ 5×11 Fix tape , Lead wire M	1		5 B3	×	TA-0012	1 roll
* 1K117-803	762	針モジュールFPC 固定テープ 5×20 Fix tape , needle module FPC	1	1B060-554	8 B3	×	TA-0012	1 roll
* 1K117-804	529	絶縁テープ, LED-FPC Insulation tape,LED FPC	1		6 B1	×	TA-0009	1 roll
* 1K117-805	763	電池室目隠しテープ 10×10 Shield tape , Battery chamber	1		6 A2	×	TA-0013	1 set (20pcs)
* 1K117-807	764	両面テープ (前カバー部) (Front cover) Double sided adhesive tape ,	1		9 A3	○		5
* 1K117-810	765	トリガー飛び防止テープ Tape.Preventing trigger skipping	1		8 B1	○		5
* 1K117-812	138	ゴミ付着防止テープ , G10 62×1.2 t=1.2 Tape , Preventing dust adhering	1		6 B1	○		5
* 1K117-814	148	漏光防止テープ 8×8 Light baffle tape	1		2 A1	○		5
* 1K117-815	183	遮光モルト Light-tight sponge	1		5 A2	○△		5
* 1K117-816	142	両面テープ Double sided adhesive tape	1		7 B2	○△		5
* 1K117-860	194	上カバーモルト Sponge. Upper cover	1		8 B3	○	RP-9454 製技94F-2015参照	5
* 1K117-862	691	遮光モルト 2 5.5×4 Light-tight sponge 2	1		2 B3	○	RP-9454	5
* 1K117-863	692	遮光モルト 3 7.5×4 Light-tight sponge 3	1		2 B3	○	RP-9454	5

部品表 Parts List

FCA28001-R. 3365. B

部品番号 Part No.	補助番号 Ckt No.	名称 Name	1台分 個数 Q'ty Per Unit	部組品番号 Assembly	参照 図番 Fig. No.	販売区分 Class. of Salabil- ity	備考 Remarks	要求単位 Order Unit Q'ty
* 1K117-911	306	絶縁シート Insulating sheet	1		6 B1	○	RP-9454	5
1K117-933	135	隙間防止テープ Take spring . Lens cover	1		6 B2	○	RP-9483 製技94F-2042	5
* 1K120-386	870	Screw	3		4 B3	○		10
* 1K120-387	876	Screw	1		4 B3	○		10
* 1K120-388	883	Screw	2		2 B1	○		10
* 1K120-389	887	Screw	2		3 B3	○		10
OLD * 1K150-093	173	パノラマレバー軸 Shaft , Panorama lever	1		2 B1	○	RP-9454 製技94F-1031参照	5
NEW * 1K150-093-1								
1K161-367	667	バリアバネスプーサー Take spring . Lens cover	1		4 D1	○		5
* 1K165-225	608	滑りシート (前部レンズ) Plastic sheet (front lens unit)	1		4 D3	○		5
* 1K165-226	705	圧接ゴム Rubber . Press contact	1		6 A1	○		5
* 1K201-108	411	コマンドダイヤル Command dial	1		8 A1	○		5
* 1K206-106	181	パノラマ操作ノブ Knob , Adjust panorama	1		8 A1	○		5
* 1K206-107	402	セレクトダイヤル Select dial	1		8 A1	○		5
* 1K220-381	405	リリース卸バネ Spring , Release button	1		8 A1	○		5

部品表 Parts List

FCA28001-R. 3365. B

部品番号 Part No.	補助番号 Ckt No.	名称 Name	1台分 個数 Q'ty Per Unit	部組品番号 Assembly	参照 図番 Fig. No.	販売区分 Class. of Salabil- ity	備考 Remarks	要求単位 Order Unit Q'ty
* 1K220-382	413	ボールバネ (411 用) Spring . Ball (For 411)	1		8 A3	○		5
* 1K220-383	452	DX バネ Spring . DX	6		4 A2	○		5
* 1K225-243	151	鍵バネ Spring . Lock cover key	1		7 A2	○		5
* 1K225-251	164	引張りバネ Spring . Panorama lever	1		2 A1	○	RP-9454 製技94F-1031参照	5
* 1K230-398	643	遊星ねじりバネ Spring . Planetary gear	1		3 B2	○		5
1K233-092	680	バリヤバネ A Spring A . Lens cover	1		4 D1	○		5
1K233-093	681	バリヤバネ B Spring B . Lens cover	1		4 D1	○		5
* 1K240-909	134	パトローネ押さえ板 Retainer plate . Patorone	1		1 A2	○		5
* 1K240-910	190	PI 押さえ板 Retainer plate . PI	1		1 A3	○		5
* 1K240-911	241	電池接片 (+側) Battery contact (+)	1		1 B1	○		5
* 1K240-912	242	電池接片 (-側) Battery contact (-)	2		1 B2	○		5
* 1K240-915	406	リリースSW台 Switch plate . Release	1		8 A3	○		5
* 1K240-917	684	FOS SWバネ1 Switch spring 1 . FOS	1		3 A2	○		5
* 1K240-918	685	FOS SWバネ2 Switch spring 2 . FOS	1		3 A2	○		5
* 1K240-919-2	687	BOS SWバネ1 Switch spring 1 . BOS	1		3 B1	○	RP-9454 製技94F-1021参照	5

部品表 Parts List

FCA28001-R. 3365. B

部品番号 Part No.	補助番号 Ckt No.	名称 Name	1台分 個数 Q'ty Per Unit	部組品番号 Assembly	参照 図番 Fig. No.	販売区分 Class. of Salabil- ity	備考 Remarks	要求単位 Order Unit Q'ty
* 1K240-920	688	BOS SWバネ2 Switch spring 2 . BOS	1		3 B1	○		5
* 1K260-660	186	デートローラー軸 Shaft . Date roller	1		1 A2	○		5
* 1K260-661	187	Dギヤ D gear	1		1 A2	○		5
* 1K260-662	215	スプール Spool	1		1 B2	○		1
* 1K260-668	646	Iギヤ2 (羽根車) I gear 2	1		3 B3	○		5
* 1K260-671	671	バリヤ開閉レバー Lens cover . O/C lever	1		4 B1	○		5
* 1K260-673	675	Bギヤ5 B gear 5	1		4 B1	○		5
* 1K260-674	676	Bギヤ6 B gear 6	1		4 B1	○		5
* 1K277-160	634	Lギヤ4-5 L gear 4-5	1		3 B3	○		5
* 1K277-161	636	Lギヤ7-8 L gear 7-8	1		3 B3	○		5
* 1K277-163	673	Bギヤ1-2 B gear 1-2	1		4 B1	○		5
* 1K277-164	674	Bギヤ3-4 B gear 3-4	1		4 B1	○		5
* 1K360-061	146	蝶番軸 Shaft . Hinge	1		7 D1	○		5
* 1K360-063	197	ストラップ軸 Shaft . Strap	1		7 C3	○		5
* 1K371-793	180	圧入ピン Pin . Slide plate	2		2 A1	○		5

部品表 Parts List

FCA28001-R. 3365. B

部品番号 Part No.	補助番号 Ckt No.	名称 Name	1台分 個数 Q'ty Per Unit	部組品番号 Assembly	参照 図番 Fig. No.	販売区分 Class. of Salabil- ity	備考 Remarks	要求単位 Order Unit Q'ty
* 1K371-798	401	リリース釦 Release button	1		8 A1	○		5
* 1K437-206	619	直進キー 2 Linear key 2	1		4 A1	○		1
1K521-223	615	前環 Front ring	1		4 D3	○		5
1K570-132	663	バリヤ Lens cover	1		4 D1	○		1
* 1K601-262	176	パノラマレバー Lever . Panorama	1		2 B1	○		5
* 1K601-263	188	D押さえ板 Retainer plate . D	1		1 A2	○		5
* 1K601-265	408	クリック板 (S) Click plate (S)	1		8 A2	○		5
* 1K601-266	414	クリック板 (C) Click plate (C)	1		8 A2	○		5
* 1K601-268	522	採光窓 Lighting window	1		8 B1	○		5
* 1K601-270	686	FOS絶縁板 Insulation plate . FOS	1		3 A2	○		5
* 1K601-271	689	BOS絶縁板 Insulation plate . BOS	1		3 B1	○		5
* 1K601-272	721	絶縁シート Insulation sheet	1		6 B3	○		5
* 1K601-294	704	圧接板C (針) Press contact plate C	1		7 C2	○		5
1K601-303	101	前カバー Front cover	1		9 B3	○		1
1K601-304	418	コマンドダイヤル板 Command dial plate	1		8 A1	○		5

品表 Parts List

FCA28001-R. 3365. B

部品番号 Part No.	補助番号 Ckt No.	名称 Name	1台分 個数 Q'ty Per Unit	部組品番号 Assembly	参照 図番 Fig. No.	販売区分 Class. of Salabil- ity	備考 Remarks	要求単位 Order Unit Q'ty
* 1K611-902	182	ノブ押さえ板 Retainer knob plate	1		8 B2	○		5
* 1K611-903	426	ファンクションSW裏打ち板 Line plate , Function switch	1		8 B3	○		5
* 1K611-911	620	FPC押さえ Retainer , FPC	1		4 A1	○		5
* 1K611-912	621	FPC ガイド板 Guide plate , FPC	1		4 A1	○		5
* 1K611-915	652	ギヤヘリ押さえ Retainer gear edge	1		4 C1	○		5
* 1K611-916	701	圧接板A (B2001) Press contact plate A	3		6 A1	○		5
* 1K611-917	703	圧接板B (LCD) Press contact plate B	1		6 A2	○		5
* 1K611-918	711	DX FPC押さえ (#1005) Retainer FPC , DX	1		5 B3	○		5
1K611-963	145	横カバー Side cover	1		7 D2	○		1
1K611-965	622	FPC押さえ Retainer , FPC	1		4 B3	○		5
* 1K611-974-1	163	バネ掛け板 Plate , Spring hook	1		2 A1	○	RP-9454 製技94F-1031参照	5
* 1K611-975-2	174	パノラマ板バネ Plate spring , Panorama	1		2 B1	○	RP-9454 製技94F-1031参照	5
1K611-986	107	前カバー当て板 Front cover plate	1		7 D3	○		1
1K611-989	136	裏蓋蝶番 Hinge , Camera back	1		7 D2	○		1
* 1K620-171	451	DX 接片 DX Contact	6		4 A2	○		5

部品表 Parts List

FCA28001-R. 3365. B

部品番号 Part No.	補助番号 Ckt No.	名称 Name	1台分 個数 Qty Per Unit	部組品番号 Assembly	参照 図番 Fig. No.	販売区分 Class. of Salabil- ity	備考 Remarks	要求単位 Order Unit Qty
* 1K625-135	126	パトローネ窓 Window , Patorone	1	1B998-193	7 B2	○△		5
* 1K641-260	109	飾りリング Decoration ring	1		9 B3	○		5
* 1K641-261	185	デートローラー Roller , Date	1		1 A1	○		5
* 1K681-407		巻戻しフォーク Rewind fork	1	1B998-084	1 A3	○△	RP-9522 サ技No95-05	5
* 1K681-629	106	三脚ねじ Tripod screw	1		5 A3	○		5
* 1K681-636	301	プロテクター Diffusor	1		8 B1	○		5
* 1K681-637	403	取付けブロック Installation block	1		8 A2	○		5
* 1K681-638	421	ファンクション釦 Function button	3		8 B2	○		5
* 1K681-642	445	DB釦 Button , DB	2		7 C2	○		5
* 1K681-643	448	保持モールド Mold	1		7 C2	○		5
* 1K681-644	455	DX 押さえ Retainer plate , DX	1		4 A2	○		5
* 1K681-653	631	ギヤ台 Plate , Gear	1		3 A3	○		1
* 1K681-654	641	系止レバー Stopper lever	1		3 B2	○		5
1K681-721	613	後飾り Rear decoration	1		4 B3	○		1
* 1K681-728	116	パトローネ規制モールド Mold , Controlling patorone	1	1B998-160	7 B2	○△		5
* 1K999-149		シャッターバクツキ防止テープ Tape , Shutter	1	1B999-754	4 D3	○△	RP-9454 製技94F-1034参照	10
1K999-158	104	底カバー Bottom cover	1		7 A3	○	製品番号 S.No 5001001~	1

部品表 Parts List

FCA28001-R. 3365. B

部品番号 Part No.	補助番号 Ckt No.	名称 Name	1台分 個数 Qty Per Unit	部組品番号 Assembly	参照 図番 Fig. No.	販売区分 Class. of Salabil- ity	備考 Remarks	要求単位 Order Unit Qty
* G1-14025FD	832	Screw	2		8 A3	○		10
* G1-14030FD	831	Screw	1		1 A2	○		10
G1-17035FS	822	Screw	1		7 B1	○		10
G1-17045FS	821	Screw	2		7 D3	○		10
* G2-14030FS	839	Screw	1		2 A1	○		10
* G2-17030FD	837	Screw	2		7 C3	○		10
G2-17035FD	836	Screw	4		7 A3	○		10
* G2-17040FA	835	Screw	2		7 D1	○		10
* G2-17050FD	834	Screw	1		7 C1	○		10
* R1-02000FY	855	LCD止め座金 Washer . Install LCD	1		6 B1	○		10
* S1-01200SX	857	Eリング (401) E ring	1		8 A1	○		10
* T1-01500SX1 (T1-01500SX)	858	ボール Ball	2		8 A3	○		10

部組番号 Part No.	補助番号 Ckt No.	名称 Name	1台分 個数 Qty Per Unit	大部組品番号 Main assembly No	参照 図番 Fig. No	備考 Remarks	要求単位 Order Unit Qty
* 1B002-078	B105	SW 部組 Switch unit	1		6 B3		1
* 1B002-079	B130	裏蓋 SW部組 Back door Switch unit	1		6 B2		1
1B002-096	B102	上カバー1 部組 Upper cover unit 1	1		8 B1		1
* 1B999-754	B604	シャッター部組 Shutter unit	1		4 D3	RP-9454 製技94F-1034参照	1
* 1B060-554	B428	針モジュール部組 Needle module unit	1		8 B3		1
* 1B240-107	B404	ブラシS部組 Brush S unit	1		8 A3		1
* 1B240-108	B416	ブラシC部組 Brush C unit	1		8 A3		1
* 1B260-104	B672	バリア開閉ギヤ部組 Lens cover , O/C gear unit	1		4 B1		1
1B535-179	B602	ヘリコイド部組 Helicoid unit	1		4 C3		1
OLD * 1B610-128	B149	裏蓋カギ部組	1		7		1
NEW * 1B610-128-4		Lock key unit , Back door			A2	パケツキ防止対策	
* 1B998-084	B234	巻き戻しフォーク部組 Rewind fork unit	1		1 A3	FCA13001	5
* 1B998-143	B1032	PI 1部組 PI unit 1	1		1 A2		1
* 1B998-144	B2201	巻き上げギヤユニット2部組 Winding gear unit 2	1		1 B2		1
* 1B998-145	B204	巻き戻し基板部組 Rewind base plate unit	1		1 A3		1
* 1B998-146	B156	パノラマ部組 Panorama unit	1		2 B2		1

部組品表 Assembly List

FCA28001-R. 3365. B

部組番号 Part No.	補助番号 Ckt No.	名称 Name	1台分 個数 Qty Per Unit	大部組品番号 Main assembly No.	参照 図番 Fig. No.	備考 Remarks	要求単位 Order Unit Qty
* 1B998-147	B175	デート遮光板部組 Light baffle plate unit	1		2 A2		1
OLD * 1B998-148	B179	スライド板部組 Slide plate unit	1		2 A1	RP-9454 製技94F-1031参照	1
NEW * 1B998-148-1							
* 1B998-149	B162	P SW基板部組 P switch base plate unit	1		2 B2		1
* 1B998-150-1 (1B998-150)	B2004	LED FPC FPC , LED	1		6 B1		1
* 1B998-153	B150	開閉ノブ部組 Lock knob unit , Camera back	1		7 A3		1
* 1B998-157	B1006	ダイヤルFPC部組 Dial FPC unit	1		8 A3		-1
* 1B998-161	B117	圧板部組 Pressure plate unit	1		7 B2		1
* 1B998-163-1 (1B998-163)	B113	電池蓋部組 Battery chamber lid unit	1		9 B2		1
* 1B998-164	B246	本体ローラー部組 Main frame roller unit	1		9 A1		1
△ * 1B998-165	B518	接眼枠部組 Eyepiece frame unit	1		9 A1	RP-0018	1
* 1B998-166	B640	遊星ギア部組 Planetary gear unit	1		3 B3		1
* 1B998-167	B649	ギア部組 Gear unit	1		3 B3		1
* 1B998-168	B1011	Lモーター部組 L Motor unit	1		3 A3		1
* 1B998-169	B2032	PI 2部組 PI unit 2	1		3 A3		1

部組品表 Assembly List

FCA28001-R. 3365. B

部組番号 Part No.	補助番号 Ckt No.	名 称 Name	1台分 個 数 Q'ty Per Unit	大部組品番号 Main assembly No.	参照 図番 Fig. No.	備 考 Remarks	要求単位 Order Unit Q'ty
* 1B998-171	B1013	赤目ランプ Lamp . Prevent red eye	1	1B998-173	3 A1		1
OLD * 1B998-173	B2531	AFブロック2部組	1		3 A1	RP-9454 サ技94-23 参照	1
NEW * 1B998-173-1		AF Block unit 2					
* 1B998-185	B440	PTS ノブ Knob unit , PTS	1		6 B2		1
1B998-189	B511	LCD LCD	1		6 B1	RP-9483	1
1B998-193	B115	裏蓋1部組 Camera back unit 1	1		7 B1		1
1B998-194	B605	前群部組 Front lens unit	1		4 D3		1
1B998-196	B610	後群部組 Rear lens unit	1		4 B3		1
1B998-201-1	B435	SBノブ部組 Knob unit , SB	1		6 B3		1
* 1B999-627-1 (1B999-627)		コインスロット部組 Coin slot unit	1	1B998-163-1	9 B2		1
1B999-708		ファインダー部組 Finder unit	1		5 A1		1
1B999-710		バリアギヤ部組 Gear unit , Lens cover	1		4 D1		5
1B999-722		暗箱部組 Dark box unit	1		3 A2		1

